

S.NO	CATALOG NUMBER	L	B	SCREW SIZE
1	NACC350-2SI	2.22 [50]	2	11/16-16
2	NACC350-3SI	3.13 [73]	3	11/16-16
3	NACC350-4SI	4.04 [96]	4	11/16-16
4	NACC350-5SI	4.95 [119]	5	11/16-16
5	NACC350-6SI	5.86 [142]	6	11/16-16
6	NACC350-7SI	6.77 [166]	7	11/16-16
7	NACC350-8SI	7.68 [189]	8	11/16-16

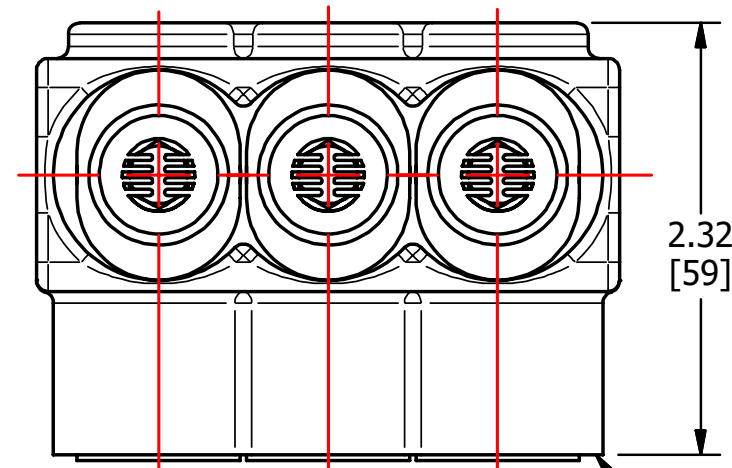

"B" PLACES
(WIRE PORT)

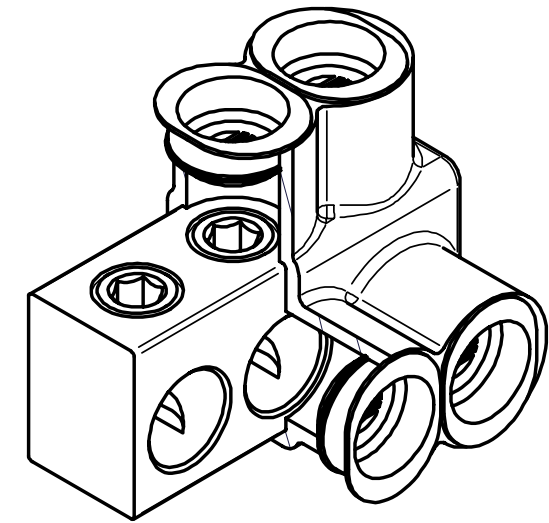

.91
[23]
TYP

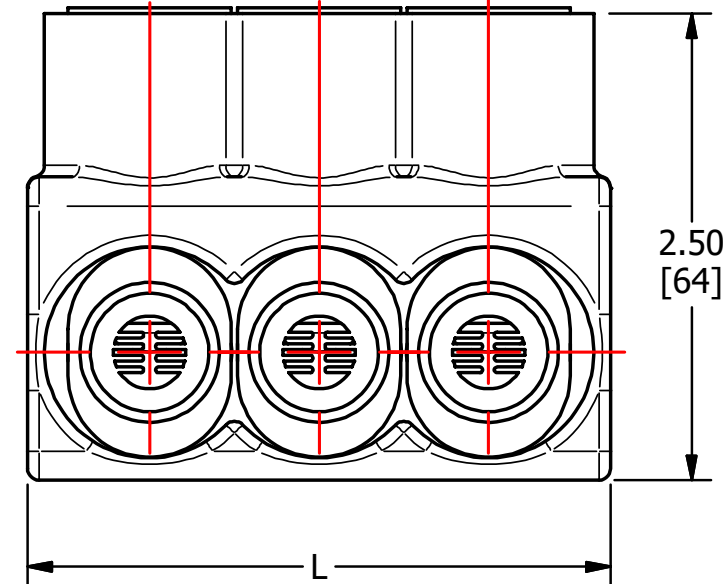

CONNECTOR FINISH: CLEAR PLATE
CONNECTOR MATERIAL: ALUMINUM
CONDUCTOR RANGE: 350 Kcmil - #12 AWG
ENCAPSULE MATERIAL: CLEAR PVC

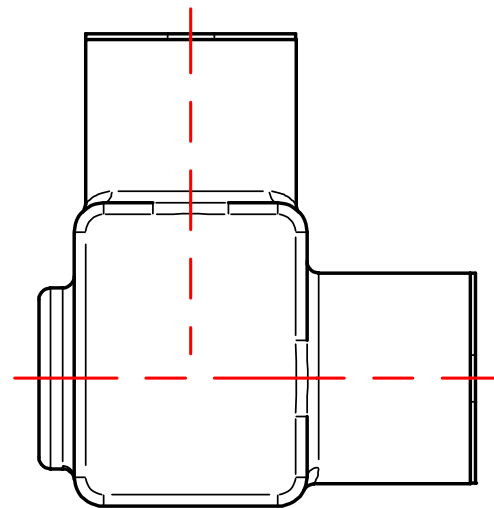

					TO ORDER CMC PRODUCTS CALL 1-513-860-4455 FOR PRODUCT INFO: http://www.cmclugs.com	DRAWN BY: TS 09-24-19 CHECKED BY:	NAME OF PART: ENCAPSULATED BAR ASSEMBLY DWG NO: C58701052I-S (CHARTED)	CAT. NO.: SEE TABLE
A	NEW DRAWING CREATED		09-24-19	TS			DRAWING NOT TO SCALE	
REV.	DESCRIPTION	ECN	DATE	INIT.				

THIS INFORMATION IS PROPRIETARY TO CONNECTOR MFG. CO. AND IS NOT TO BE DISCLOSED OUTSIDE OF CONNECTOR MFG. CO. WITHOUT A CONFIDENTIALITY AGREEMENT



CONNECTOR MANUFACTURING CO.

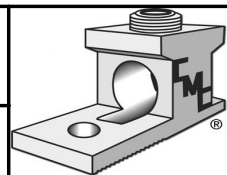

HAMILTON, OHIO